

# Getting Started with AgroCares Scanner Serie F

Instruction manual guiding you through the process  
from setting up your user profile, entering the license  
to scanning your first sample





## Content

This manual explains how to get started with your AgroCares Scanner. To make the most of this innovative solution, please take the time to read this document carefully.

1. General information – Before Shipment
2. Box content
3. Preparing the Scanner
4. Installing the mobile application
5. Registration
6. Start-up and connect
7. Scanning
8. AgroCares Online Portal
9. Support



## 1. General Information – Before Shipment

### Quality check

All AgroCares Scanners undergo a quality check before they are shipped to the end user. The quality control is done by AgroCares support technicians to ensure that the Scanner you receive works properly and that the results it provides meet our accuracy standards. For example, they test the Bluetooth connectivity, battery, parameters and calibration (cap).

Please note that this quality check requires scanning a real sample and as a result, some minor traces of use might be visible on your Scanner. We take great care to minimize these. After performing the quality check, the Scanners are cleaned thoroughly and carefully.

Please keep in mind that every AgroCares Scanner is handmade and constructed out of die-cast aluminium. Hence, no two Scanners will look precisely the same.

### This Scanner has passed the AgroCares Quality Control Test

Fingerprints and soil/feed traces can sometimes be found on the Scanner and inside the box. These are the result of the final quality control test performed by the AgroCares technical team before Shipment.

Pre-shipment inspection is performed on every newly manufactured AgroCares product before they are shipped to the customer to ensure the absence of any hardware defects. This consists of unpackaging the Scanner, connecting Scanner to AgroCares mobile application via Bluetooth, scanning for calibration, and scanning samples of soil and/or feed five times to complete the order. If the order is successfully completed and the report is generated, the Scanner has passed the final Quality Control test and is ready for Shipment to the customer. This way, AgroCares guarantees that the Scanner meets our best quality standards. Quality Control tests are performed by AgroCares technical team and can result in spotting soil particles and fingerprints.

### Internet connection

AgroCares Scanner is used in combination with one of our mobile applications. A stable internet connection is required to log in, scan and synchronize your data.

It is also possible to scan a sample without the internet and synchronize it later. Ensure you do not log out or close the app before synchronization is completed. This prevents the loss of your data.

## 2. Box Content

Your Scanner is delivered in a cardboard box.

The box includes:

Scanner case

The Scanner: The handheld unit that performs the scan

Calibration cap: Cap for 'standard sample' and 'background scan' calibrations

Scanner charger: USB-C type cable + power supply adapter

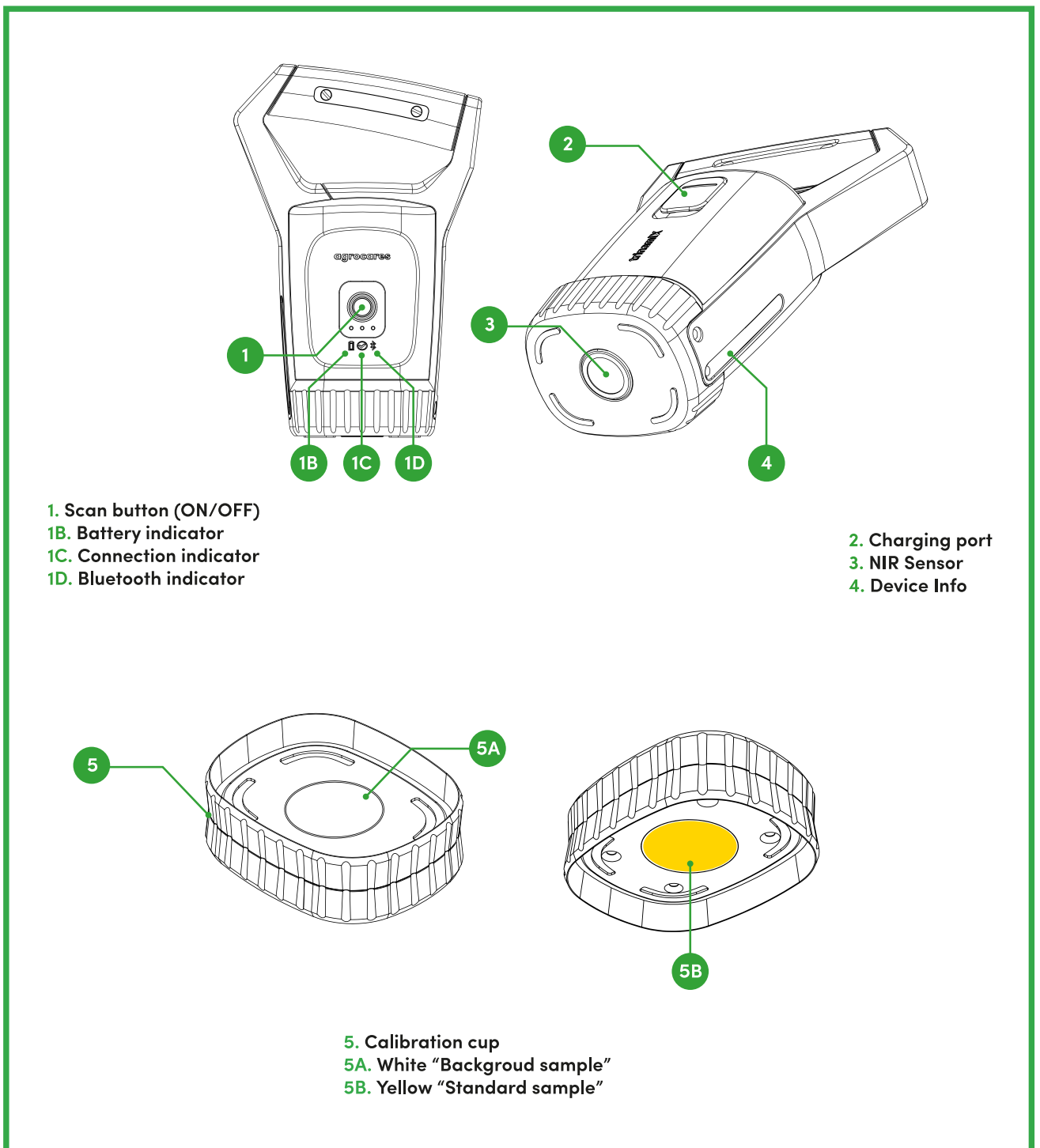

## Accessories

Cleaning products:	Brush and cloth for cleaning the device
Quick reference card:	Two-page instruction document
Sample tray/cup:	A tray/cup for scanning a feed, leaf or soil sample

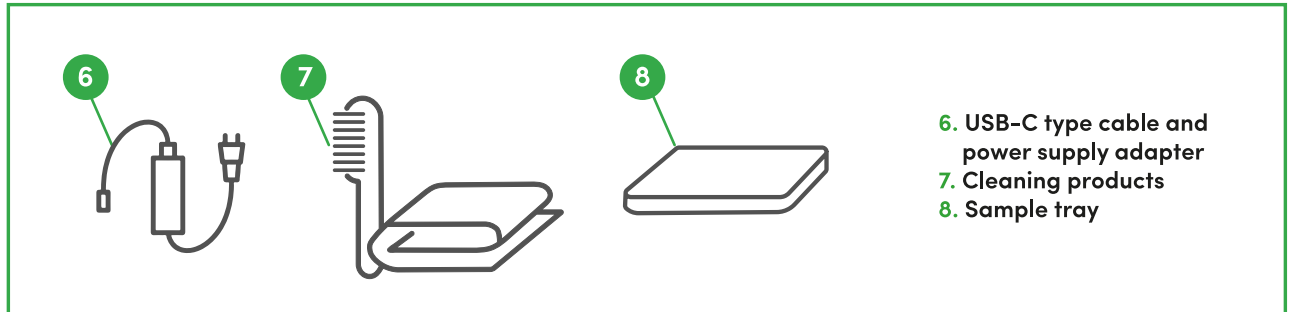

### 3. Preparing the Scanner

To maximize the lifespan of your Scanner, prepare it for use by following the steps below.

#### Charging instruction

Charge the battery by connecting the USB cable to the power socket and the charging port on your Scanner.

Due to IATA regulations for shipping batteries, it is not allowed to ship fully charged devices, please make sure you charge the Scanner till **full charge**. Please note the battery cannot be charged if the device temperature is too high. In this case, allow the device to cool down. The device should be charged at room temperature, not exceeding 30 °C/86 °F.

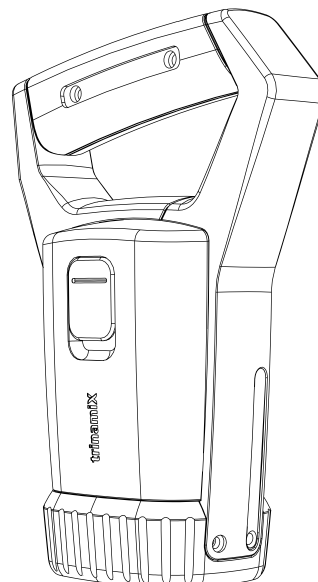



## Battery Indicator

Red blinking, 1x/1 s	Battery capacity < 4 % (device in power save mode)
Red blinking, 3x/1 s	USB PD charger not compatible
Green flashing, 1x/2 s	Charging (USB PD charger connected)
Green/red blinking, 1x/1 s	Battery level < 10 % (no USB PD charger connected)
Green blinking, 1x/1 s	Battery level < 30 %
Green	Battery level high
Off	Device off, no USP PD charger connected

For more information on the charging, you can consult our support page or contact the helpdesk: [support@agrocares.com](mailto:support@agrocares.com)



**Before first use or if the Scanner has not been used for more than four weeks, charge the Scanner till full charge.**

### Power usage

On a fully charged battery, the Scanner can perform around 5000 Scans/ approximately 700 samples. For a full recharge the Scanner should be charged for about 3 hours (at European voltage 220V-240V).

Charge the battery every 3 months even if you are not using the Scanner, to avoid any damage to the battery.



## 4. Installing the Mobile Application

Downloading the mobile application

You can download the AgroCares Scanner Solution app from the App Store or the Google Play Store.

To use the apps, you will need a valid license key. The license key can be purchased from AgroCares webshop:

<https://webshop.agrocares.com/license.html>

### Smartphone requirements

The AgroCares Scanner is operated with Android phone (8.0 version or higher) and iPhone 11 or above with iOS (13 version or higher). To download the apps from the Play Store, your Google Play account should have a device certification. This certification can be found in the Google Play Store setting under 'Device certification'.

Once you have downloaded the app, it will request access to the images and location data of your device. The access is required to register the sample locations in order to connect to the correct database.



## 5. User Registration

### Logging in to the mobile app

To log in to the mobile app, you first need to register as a new user. Fill in your name, email and choose your password. Tick the checkbox to agree to AgroCares terms and conditions and press Register.

You will then be asked to enter your license key to get access to the app.

Your username will be valid for all AgroCares Platforms, the Application and Management Portal.

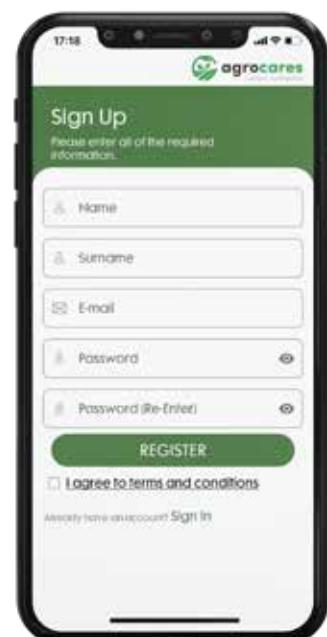

## 6. Start-up and connect

### Turn the Scanner on

Press the round button for 1 second. The lights on the device indicating the battery, the Bluetooth and the measurement light will light up (red/green). The Scanner is ready to connect to the phone.

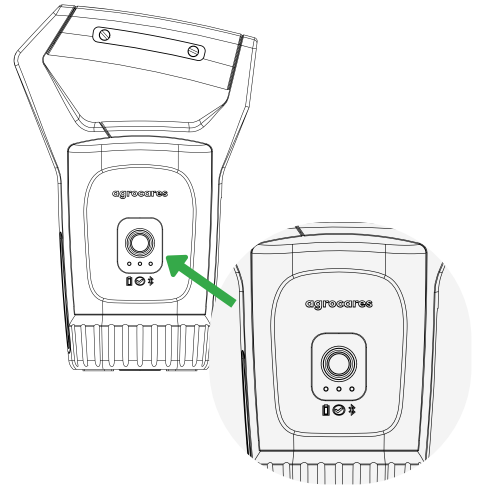

### Connect the Scanner to your mobile application

The Scanner name is located on the back side of the handle frame (see image). The Scanner name consists of the letters SC, three to four digits and a letter. The letter indicates the device version.

Open AgroCares app. Go to the menu 'Account'. Click on <Select Scanner> in the bar Device Settings. If you previously connected the Scanner to your phone, you will find the device in the PAIRED DEVICES list.

If the connection between phone and the Scanner is new, click on 'Search for Devices' and select your Scanner name from the AVAILABLE DEVICES list.

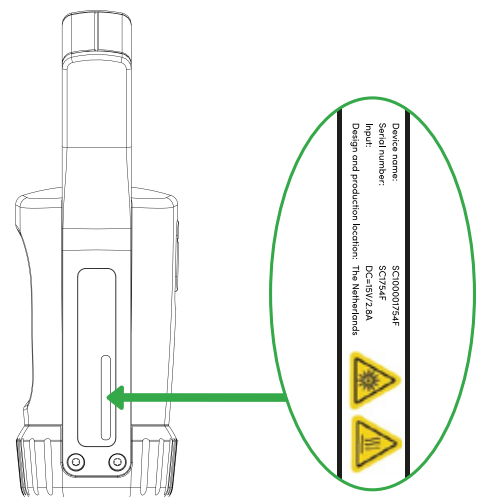

When the connection between your phone and Scanner is set, the Bluetooth light will have a green blinking light (1x/1s). If the connection is not successful, the blinking light will be red.



## 7. Scanning

Open the app and select the 'Scan' menu in order to start the scanning process. The 'scan' menu can also be accessed via the client and field data.

The app always indicates which scan is needed. When the scan has been finalized a "green tick" will be displayed in the scanning step and your phone will vibrate (if this is switched on in our phone settings).

The Scan button on the app will turn green when it is ready to scan. You can press the button on the app or on the device itself. The Scan button on the app will turn grey when it is scanning or not ready to start the next scan.



**Important: Do not move the Scanner during the scanning process!**

### Calibration of the Scanner (two steps)

The Scanner lights indicate that the Scanner needs to be calibrated by the measurement light blinking red (1x/1s). The app will also indicate when that is necessary – always before scanning a sample.

#### 1. Open Air Scan

Point the Scanner towards the ground at about 0.5-1 meters from the ground and press the Scan button. Do not cover the glass surface and do not point at a reflecting surface.

## 2. Calibration Cap Scan

White background scan with the calibration cap:

- Before each order, a white-background calibration needs to be performed with the calibration cap.
- Check if the sensor head and glass plate are clean from dirt and moist. If necessary, clean it with the brush and/or tissues.
- When the Scanner is clean, place it in the calibration cap facing the white side. The Scanner head needs to be in contact with the white surface.
- Start the scanning process by pressing the 'scan' button on the device or on the phone.

Yellow standard scan with the calibration cap:

- If the application requests, a yellow standard sample may need to be performed with the yellow side of the calibration cap.
- Turn the calibration cap with the yellow side facing upwards, and position the sensor pins inside the holes of the calibration cap.
- The Scanner head needs to be in contact with the yellow surface of the calibration cap.

Start the scanning process by pressing the 'scan' button in the app for on the device for one second.



**Note: Keep the yellow side of the calibration cap clean but do not clean it as this may damage the cap!**

If the background or standard scan has not been successful, an error message will show in the app. Follow the instructions to resolve the issue. If the issue persists, please contact support via [support@agrocares.com](mailto:support@agrocares.com).

When the calibration process is finished, you will be redirected automatically to the sample scanning process.

### Scanning your sample

A sample must be prepared before you can start scanning. Prepare a big enough sample to represent your testing area. In total, five scans are required to provide an accurate measurement of your sample. The Scanner will be delivered with a sample tray and/or a sample cup. We recommend you to use the sample tray when scanning a feed or leaf sample and the sample cup when scanning a soil sample.

To scan your sample, please follow these steps:

### Step 1

Using the tray: Mix the sample well and fill the sample tray with 4-5 cm of material.

Using the cup: Mix the sample well in a bucket and take for each scan a full scoop of material (about 250gr of soil).



### Step 2

Place the Scanner on top of the sample. Make sure the scanning surface of the sensor head is in contact with the sample.

### Step 3

Press the 'Scan' button for 1 second or press the scan button on the phone screen to start the scanning process. Do not move the Scanner while it is scanning or while the scan (green) light is blinking.



### Step 4

The mobile app will notify you when you can continue to the next scan. Five scans per sample are required.

### Step 5

Clean the sensor head before proceeding with the second scan.

### Step 6

Using the tray: Place the Scanner on a new location on the sample tray and press the Scan button.

Using the cup: Take for each scan a new full scoop of soil from the collected soil sample in the bucket, it and press the Scan button.



### Step 7

Repeat the process until all 5 required valid scans are finalized. During each scan, make sure the scanning surface of the sensor head is in contact with the sample. Clean the sensor head between each scan.

### Step 8

Clean the Scanner properly before placing it back in the case. After completing these steps, follow the process in the app to register a client, a field and to generate a report.



## Cleaning the Scanner after and between use

The Scanner is a near-infrared (NIR) measuring device. You must take good care of your Scanner head to ensure its proper operation. Keep the bottom and glass parts of the Scanner clean by using the brush and the dry-cleaning wipes after each scan.

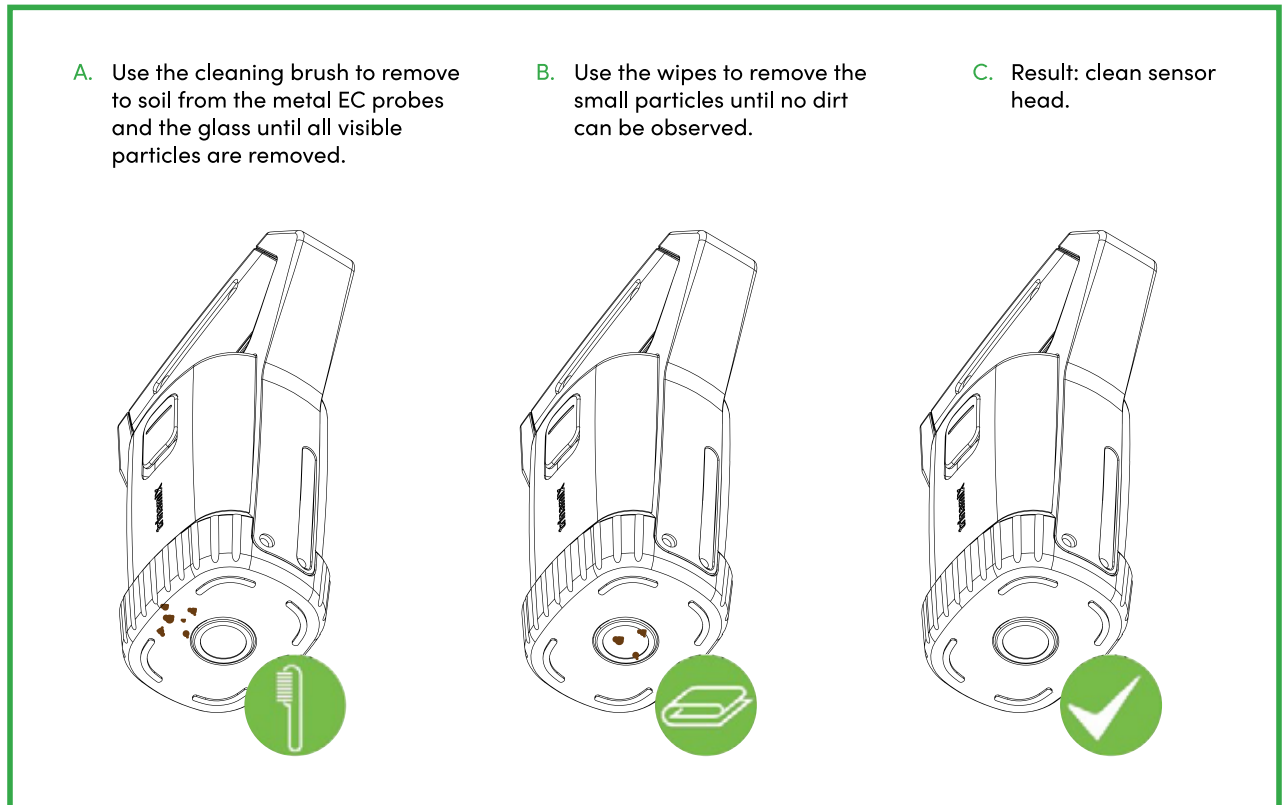

## Cleaning the calibration cap

The white side of the cap needs to be kept clean. The yellow side needs to be kept clean and dry. It is not possible to clean the yellow side of the cap. Moisture will damage the yellow surface. If the calibration cap is not properly maintained, a replacement of the cap might be necessary. Therefore, it is important to keep the Scanner clean before it is placed on the calibration cap.

Calibration will not be possible if the white side is not completely white anymore or if the fibers of the yellow side are loose. In that case, a replacement of the calibration cap is needed.

## 8. AgroCares Online Portal

AgroCares Online Portal is available at: [portal.soilcares.com](https://portal.soilcares.com)

To log in to the Portal, use the same credentials as the ones you registered in the mobile application.

The Portal makes working with the Scanner even easier and helps you to get more from your data. It contains a dashboard with graphs and charts based on your scans. It gives you an overview of all your clients and fields and a full overview of all your orders.

You can register your clients and fields online and easily edit their information. All updated information is synchronized to your app and ready to be used when you are back in the field. You can view and download all your PDF reports directly to your computer and export all your data and results to an Excel spreadsheet.



## 9. Support

### Frequently Asked Questions (FAQ)

Open the app and select the 'Start' menu in order to start the scanning process. The 'start' menu can also be accessed via the client and field data.

The device is ready to scan when the Scan button in the app is green.

The app always indicates which scan is needed. When the scan has been finalized an 'OK' symbol will be displayed in the scanning step and your phone will vibrate (if this is switched on in our phone settings).

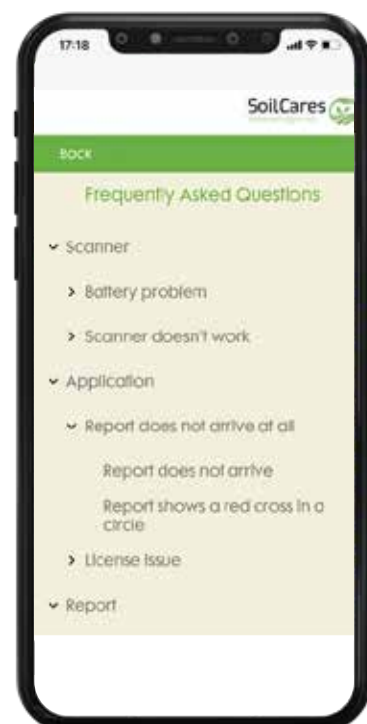

## Support page

You can find more instructions, tips on how to make the best use of your Scanner and advice on how to properly clean and maintain your Scanner on our support webpage: [support.soilcares.com](https://support.soilcares.com)

## How to contact us?

You can contact our support team by email:  
[support@agrocares.com](mailto:support@agrocares.com)

Alternatively, you can submit a request via the support page:  
[support.soilcares.com](https://support.soilcares.com)

## Read more

[www.agrocares.com](https://www.agrocares.com)  
[www.support.soilcares.com](https://www.support.soilcares.com)

## Warnings



Avoid eye contact with the light source of the Scanner!



Burn hazard: The bottom parts of your Scanner are hot during use. Do not touch the bottom parts unless the Scanner is turned off and has cooled down.

This document has been last updated in March 2024.  
The most recent information is always available on AgroCares support webpage or in the within-app guidance and FAQ.

